

PANELTIM[®]

Pioneer in plastic sandwich panels

Paneltim[®] Venti[®]
for optimal air circulation
in your barn



Paneltim® Venti®

AVAILABLE IN DIFFERENT COLOURS & SIZES

PANELTIM® VENTI® - 35 MM

Depth: 35 mm
Openings: 350 mm x 30 mm every 100 mm
Sizes: 1,200 mm x 800 mm
1,200 mm x 1,000 mm
Weight: ± 8 kg/m²
Cells: 100 mm x 50 mm
Wall thickness: 3.5 mm

Material: PP COPO
Recycled | Near to Prime

Recycling code:



PANELTIM® VENTI® - 50 MM

Depth: 50 mm
Openings: 350 mm x 30 mm every 100 mm
Size: 1,200 mm x 1,000 mm
Weight: ± 9 kg/m²
Cells: 100 mm x 100 mm
Wall thickness: 3.5 mm



Material: PP COPO
Recycled | Near to Prime

Recycling code:



PANELTIM® DOUBLE VENTI® - 50 MM



Depth: 50 mm
Openings: 2 rows:
350 mm x 30 mm every 100 mm
Size: 1,200 mm x 1,000 mm
Weight: ± 11 kg/m²
Cells: 100 mm x 100 mm
Wall thickness: 3.5 mm

Material: PP COPO
Recycled | Near to Prime

Recycling code:



INTERNAL MEASUREMENTS OF THE OPENING

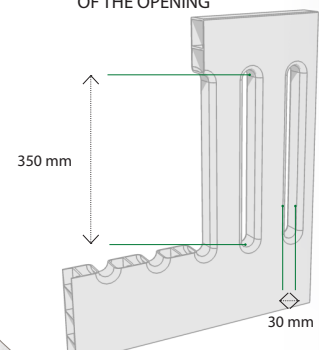

SEVEN REASONS TO CHOOSE PANELTIM® VENTI® PANELS

1. BETTER AIR CIRCULATION

The slits in the panels ensure better air circulation throughout the barn. Animals enjoy the air that flows through the openings in pen partitions and alleys walls where Paneltim® Venti® panels have been installed.

2. REDUCES STRESS THROUGH VISUAL CONTACT

Using Venti® panels helps diminish the “boxed-in effect”. This, in turn, reduces stress on the animals. They can see each other through the small slits, but have little to no physical contact. This also reduces the risk of germ transmission.

3. MANAGING EXCRETORY BEHAVIOR

Since they have visual contact, the animals can see each other through the Venti® panels where they will also defecate and urinate. A partially warm and cold floor or closed and open floor can be extended into the pen partition.

4. OPTIMAL HYGIENE

The internal cell structure of Paneltim® panels ensures that all sides of the panel are always closed (even when cut to size). This prevents the internal accumulation of dirt, fungi, or bacteria. The surface is smooth and non-porous. This makes the panels water- and dirt-repellent and non-absorbent. Panels can then be cleaned quickly and easily using a pressure washer. This means Paneltim® panels contribute to improving the internal biosafety of your barn by helping to reduce water consumption.



5. LIGHT BUT STRONG

Because of their 100 mm x 100 mm or 100 mm x 50 mm internal cell structure, Paneltim® panels are light but rigid and strong. Panels do not discolor when they come into contact with ammonia.

6. EASY INSTALLATION AND QUICK ASSEMBLY

Paneltim® Venti® panels can be easily installed using standard hand tools such as a saw, drill, and screws, and by cutting and welding. The panels can easily be welded into various sizes and dimensions. Larger dimensions are surprisingly easy to handle because of the panels' light weight.

7. ECO-FRIENDLY

Paneltim® Venti® panels are often produced using 100% recycled materials (PP COPO). The panels are 100% recyclable and retain their raw material value.

CUSTOMIZATION

Venti® panels can be cut to size with variable heights using hot plate welding. The number of slots can also be limited or a combination panel can be made that consists partly of closed panels and partly of Venti® panels. This provides a quick and easy solution for managing animals' excretory behavior.

MATERIAL

Paneltim® plastic panels are made of polypropylene copolymer (PP COPO) and are coloured throughout. The characteristics of PP COPO are that it is very strong, wear-resistant and easy to clean. With a high-pressure cleaner you can clean the Venti® panels in no time at all. The smooth surface of the panels is non-absorbent, water and dirt repellent, and dries quickly, ideal for animal housing.

EXTRA FLEXIBILITY DUE TO INTERNAL DOUBLE RIB

The 35 mm Venti® panels have an internal 'double rib' with just enough room for a saw blade. This makes it possible to separate the closed part from the part with the openings. The separate parts have a closed edge which prevents the internal accumulation of dirt and bacteria. This offers enormous flexibility because you can make even more combinations without losing any material. After all, you can use any residual material elsewhere in your barn.

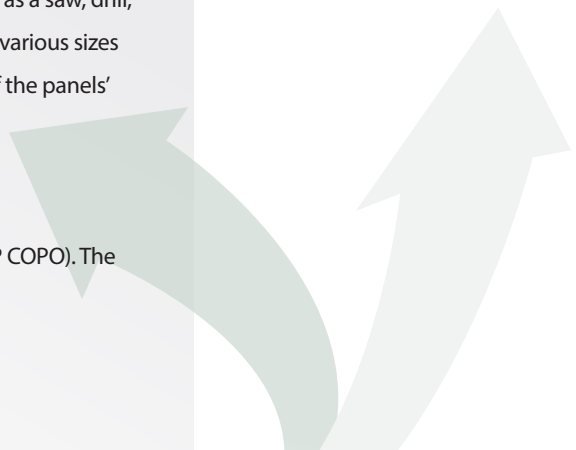

COMBINING TO CREATE SMART SOLUTIONS



When one part of the pen partition must be closed and another requires venti slits, combining 35 mm Paneltim® Venti® panels with 35 mm Paneltim® Ultralight panels offers a solution for **smaller animals**.

For **larger animals**, combine 50 mm Paneltim® Venti® panels with 50 mm Paneltim® Lightweight panels. The designs and options are endless. Even lengths of up to 6 meters are possible.



A SELECTION OF THE POSSIBILITIES OF PANELTIM® VENTI®:

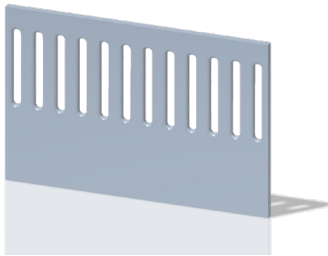

- Maximum visual contact with minimum physical contact
- Stress reducing

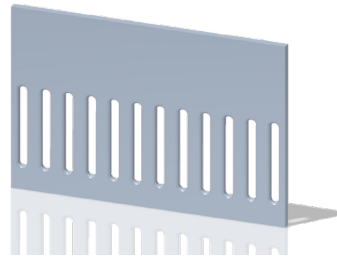

- For even the smallest of piglets
- Visual contact and management of dunging behaviour from the very start

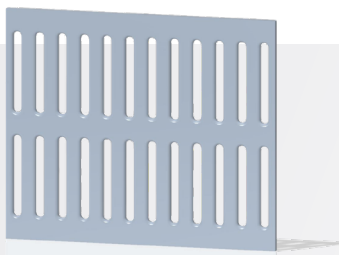

- More airflow
- Less stress
- More control of dunging behaviour

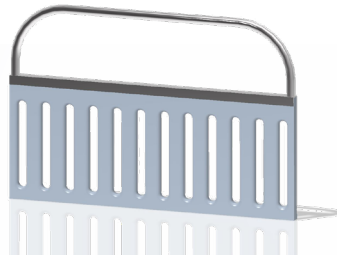

- Ideal for warm countries
- More airflow
- Openings at the bottom prevent rust



Mail: sales@paneltim.com
WWW.PANELTIM.COM